

8" MULTI-PLY BELLOWS

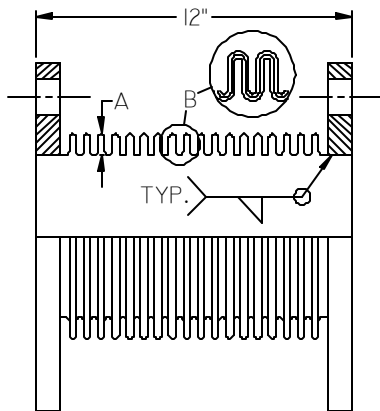

- TALLER CORRUGATION HEIGHT (A) PROVIDES GREATER FLEXIBILITY AND COMPRESSION CAPABILITY TO ABSORB VIBRATION AND THERMAL EXPANSION OF THE PIPING
- MAX. AXIAL COMPRESSION = 4.0"
- AXIAL SPRING RATE = 123 lb/in
- MAX. LATERAL OFFSET = 1.0"
- LATERAL SPRING RATE = 109 lb/in
- WELDING IS DONE ON THE BELLOWS NECK KEEPING THE HEAT AFFECTED ZONE AWAY FROM THE CORRUGATION STRESS POINT.
- MULTI-PLY CONSTRUCTION PROVIDES THE LOWEST SPRING RATES AND SUPERIOR VIBRATION DAMPENING CHARACTERISTICS.
- COMPUTER ENGINEERED PRODUCT WITH PRE-DETERMINED CYCLE LIFE.
- BEST SUITED FOR PRIME POWER, MARINE, CO-GENERATION, OR ANY CRITICAL APPLICATION WHERE DOWN TIME IS A PROBLEM.

8" EXHAUST FLEX

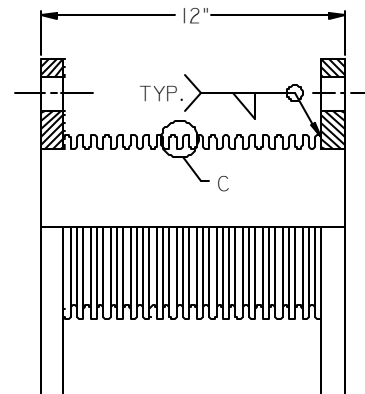

- SHALLOW CORRUGATION HEIGHT (C) HAS LIMITED CAPABILITY. THIS PRODUCT IS NOT DESIGNED TO ABSORB THERMAL EXPANSION OF THE PIPING SYSTEM.
- MAX. AXIAL COMPRESSION = .21"
- AXIAL SPRING RATE = 680 lb/in
- MAX LATERAL OFFSET = .30"
- LATERAL SPRING RATE = 457 lb/in
- WELDING MUST BE DONE ON THE CORRUGATION RADIUS. THIS STRESS POINT IS IN THE HEAT AFFECTED ZONE AND IS THE FIRST TO FAIL.
- MULTI-PLY CONSTRUCTION NOT AVAILABLE.
- UNPREDICTABLE CYCLE LIFE.
- SUITABLE FOR NON-CRITICAL OR STAND-BY APPLICATIONS WHERE DOWN TIME IS NOT A FACTOR.

FOR MORE INFORMATION, CONTACT YOUR LOCAL SALES REPRESENTATIVE OR GIVE D.M.E. A CALL. LET OUR SALES/ENGINEERING STAFF ASSIST YOU IN SELECTING THE RIGHT PRODUCT FOR YOUR APPLICATION.

D.M.E. INCORPORATED

14001 MARQUARDT AVE.
SANTA FE SPRINGS, CA 90670

TEL: (562) 921-0464

FAX: (562) 802-7489

URL: www.dmeexpansionjoints.com